

RPLIDAR A1

Low Cost 360 Degree Laser Range Scanner

Introduction and Datasheet

Model: A1M8

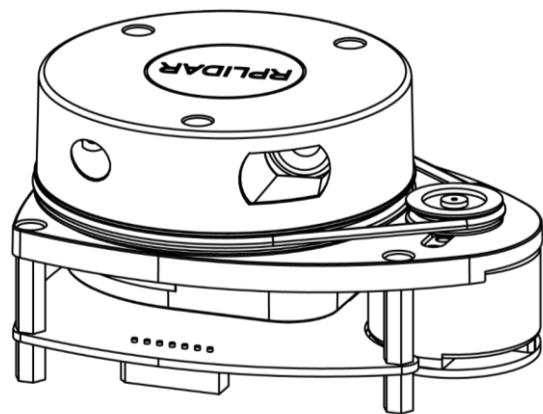

CONTENTS	1
INTRODUCTION	3
SYSTEM CONNECTION	3
MECHANISM	4
SAFETY AND SCOPE	5
DATA OUTPUT	6
APPLICATION SCENARIOS	7
SPECIFICATION	8
MEASUREMENT PERFORMANCE	8
LASER POWER SPECIFICATION	9
COMMUNICATION INTERFACE.....	9
POWER SUPPLY AND CONSUMPTION.....	11
MISC.....	12
SELF-PROTECTION AND STATUS DETECTION	13
SDK AND SUPPORT	14
MECHANICAL AND CUSTOMIZATION OPTIONS	15
REVISION HISTORY	17
APPENDIX	18
IMAGE AND TABLE INDEX	18

RPLIDAR A1 is a low cost 360 degree 2D laser scanner (LIDAR) solution developed by SLAMTEC. The system can perform 360 degree scan within 12-meter range (6-meter range of A1M8-R4 and the belowing models) . The produced 2D point cloud data can be used in mapping, localization and object/environment modeling.

RPLIDAR A1's scanning frequency reached 5.5 hz when sampling 1450 points each round. And it can be configured up to 10 hz maximum.

RPLIDAR A1 is basically a laser triangulation measurement system. It can work excellent in all kinds of indoor environment and outdoor environment without direct sunlight exposure.

System connection

RPLIDAR A1 contains a range scanner system and a motor system. After power on each sub-system, RPLIDAR A1 start rotating and scanning clockwise. User can get range scan data through the communication interface (Serial port/USB).

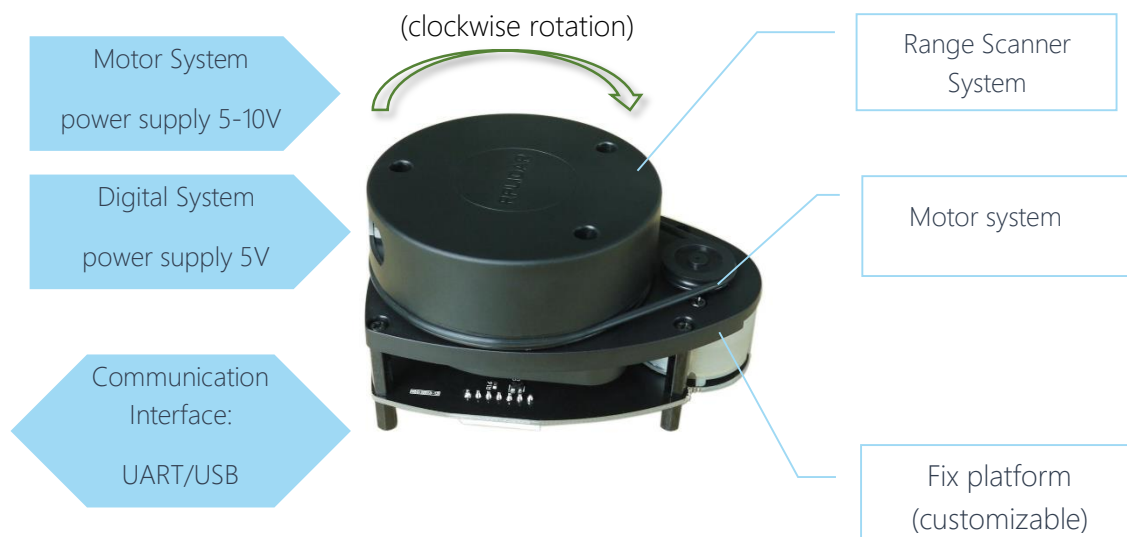

Figure 1-1 RPLIDAR A1 System Composition

RPLIDAR A1 comes with a speed detection and adaptive system. The system will adjust frequency of laser scanner automatically according to motor speed. And

host system can get RPLIDAR A1's real speed through communication interface. The simple power supply saves LIDAR system's BOM cost and makes RPLIDAR A1 much easier to use. Detailed specification about power and communication interface can be found in the following sections.

Mechanism

RPLIDAR is based on laser triangulation ranging principle and uses high-speed vision acquisition and processing hardware developed by SLAMTEC. The system measures distance data in more than 8000 times' per second^① and with high resolution distance output (<1% of the distance).

RPLIDAR emits modulated infrared laser signal and the laser signal is then reflected by the object to be detected. The returning signal is sampled by vision acquisition system in RPLIDAR A1 and the DSP embedded in RPLIDAR A1 start processing the sample data and output distance value and angle value between

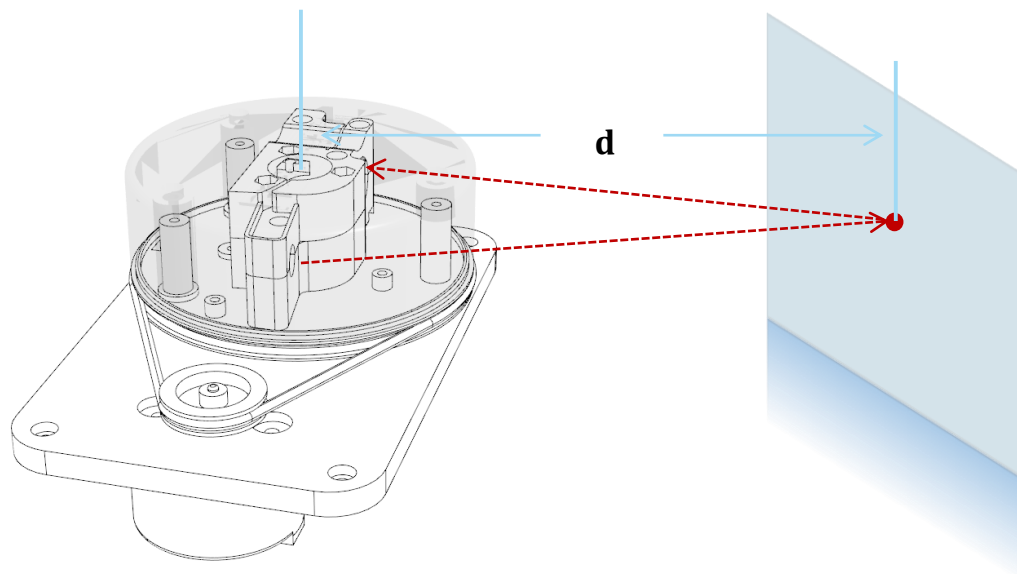
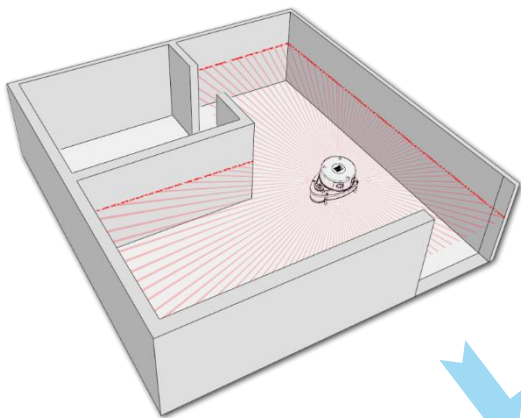

Figure 1-2 The RPLIDAR A1 Working Schematic

^① R1 and R2 models only support the radar 2k times per second ranging frequency. R3 and R4 models need to update the firmware to 1.24 to support 8k times per second ranging frequency.

object and RPLIDAR A1 through communication interface.

The high-speed ranging scanner system is mounted on a spinning rotator with a build-in angular encoding system. During rotating, a 360 degree scan of the current environment will be performed.



*Note: The LIDAR scan image is not directly relative to the environment showed here. Illustrative purpose only.

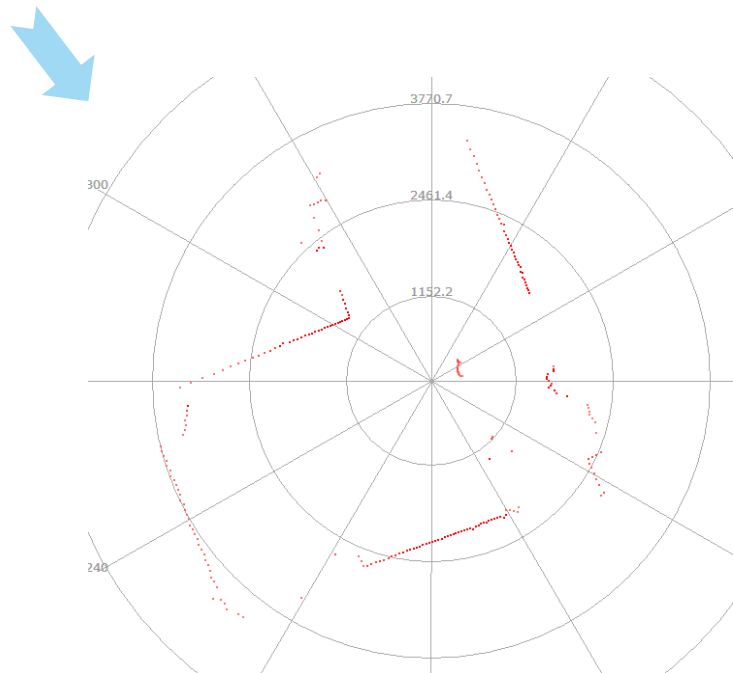

Figure 1-3 The Obtained Environment Map from RPLIDAR A1 Scanning

Safety and Scope

RPLIDAR A1 system use a low power (<math><5\text{mW}</math>) infrared laser as its light source, and drives it using modulated pulse. The laser emits in a very short time frame which can make sure its safety to human and pet and reach Class I laser safety standard. Complies with 21 CFR 1040.10 and 1040.11 except for deviations pursuant to Laser



Class I

Notice No. 50, dated June 24, 2007.

Caution: Use of controls or adjustments or performance of procedures other than those specified herein may result in hazardous radiation exposure.

The modulated laser can effectively prevent ambient light and sunlight during ranging scanning process. This make RPLIDAR A1 work excellent in all kinds of indoor environment and outdoor environment without sunlight.

Data Output

During the working process, the RPLIDAR A1 will output the sampling data via the communication interface. And each sample point data contains the information in the following table. If you need detailed data format and communication protocol, please contact SLAMTEC.

Data Type	Unit	Description
Distance	mm	Current measured distance value between the rotating core of the RPLIDAR A1 and the sampling point
Heading	degree	Current heading angle of the measurement
Quality	level	Quality of the measurement
Start Flag	(Boolean)	Flag of a new scan

Figure 1-4 The RPLIDAR A1 Sample Point Data Information

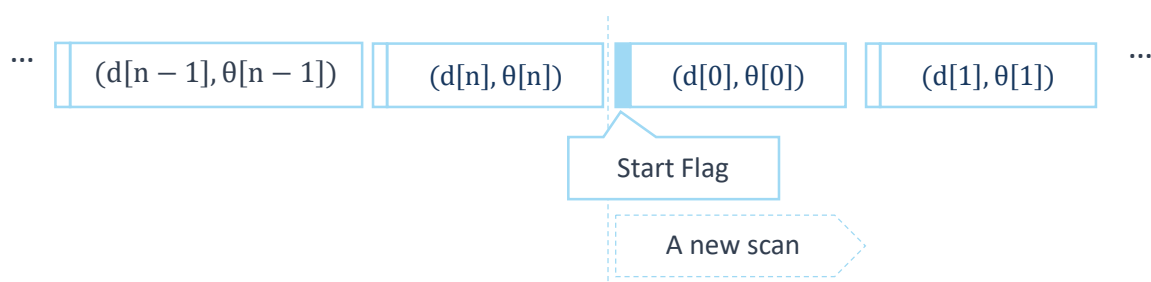

Figure 1-5 The RPLIDAR A1 Sample Point Data Frames

The RPLIDAR A1 outputs sampling data continuously and it contains the sample point data frames in the above figure. Host systems can stop RPLIDAR A1 output data by sending stop command. When using 4k and above sampling frequency,

the transmission data structure is different. For more information please contact SLAMTEC.

Application Scenarios

The RPLIDAR A1 can be used in the following application scenarios:

- Home service /cleaning robot navigation and localization
- General robot navigation and localization
- Smart toy's localization and obstacle avoidance
- Environment scanning and 3D re-modeling
- General simultaneous localization and mapping (SLAM)

Measurement Performance

○ For Model A1M8 Only

Item	Unit	Min	Typical	Max	Comments
Distance Range	Meter(m)	TBD	A1M8-R4 and the belowing models	0.15 - 6	TBD White objects
			A1M8-R5	0.15-12	
Angular Range	Degree	n/a	0-360	n/a	
Distance Resolution	mm	n/a	<0.5 <1% of the distance	n/a	<1.5 meters All distance range*
Angular Resolution	Degree	n/a	≤1	n/a	5.5Hz scan rate
Sample Duration	Millisecond(ms)	n/a	0.125	n/a	
Sample Frequency	Hz	n/a	≥8000	8010	
Scan Rate	Hz	1	5.5	10	Typical value is measured when RPLIDAR A1 takes 360 samples per scan

Figure 2-1 RPLIDAR A1 Performance

Note: the triangulation range system resolution changes along with distance, and the theoretical resolution change of RPLIDAR A1 is shown as below:

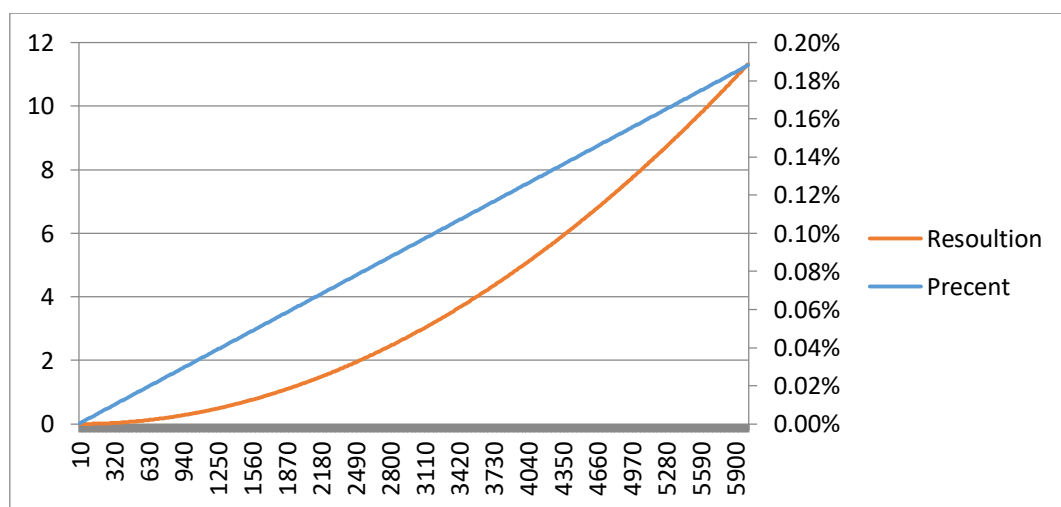

Figure 2-2 The Trend Graph of RPLIDAR A1 Resolution

Laser Power Specification

- For Model A1M8 Only

Item	Unit	Min	Typical	Max	Comments
Laser wavelength	Nanometer(nm)	775	785	795	Infrared Light Band
Laser power	Milliwatt (mW)	TBD	3	5	Peak power
Pulse length	Microsecond(us)	TBD	110	300	

Figure 2-3 RPLIDAR A1 Optical Specification

Communication interface

RPLIDAR A1 uses 3.3V-TTL serial port (UART) as the communication interface. Other communication interface such as USB can be customized according to customer's requirement. The table below described specification for serial port interface. Please contact SLAMTEC if you want detailed communication protocol and SDK.

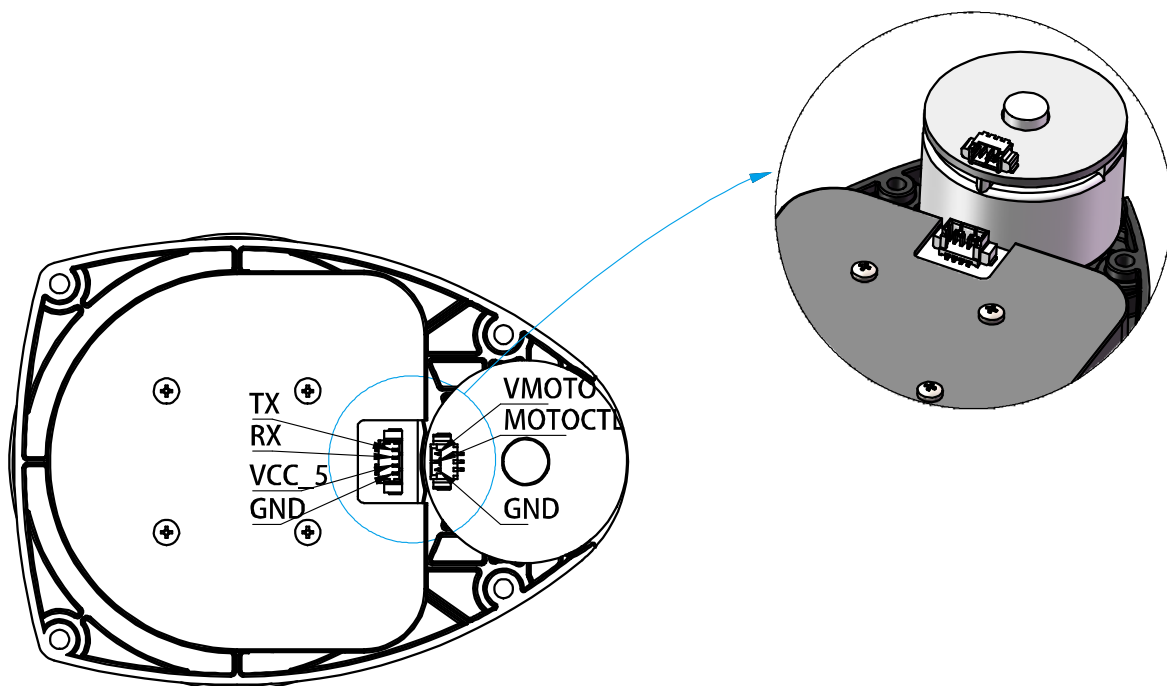

Figure 2-4 RPLIDAR A1 Power Interface

Item	Unit	Min	Typical	Max	Comments
Band rate	bps	-	115200	-	
Working mode	-	-	8N1	-	8n1
Output high voltage	Volt (V)	2.9	-	3.5	Logic High
Output low voltage	Volt (V)	-	-	0.4	Logic Low
Input high voltage	Volt (V)	1.6*	-	3.5	Logic High
Input low voltage	Volt (V)	-0.3	-	0.4	Logic Low

Figure 2-5 RPLIDAR External Interface Signal Definition

Note: the RX input signal of A1M8 is recognized by the current. In order to ensure the reliable signal identification inside the system, the actual control node voltage of this pin will not be lower than 1.6v.

Interface	Signal Name	Type	Description	Min	Typical	Max
Motor Interface	VMOTO	Power	Power for RPLIDAR A1 Motor	-	5V	9V
	MOTOCTL	Input	Enable signal for RPLIDAR A1 Motor/PWM Control Signal	0V	-	VMOTO
	GND	Power	GND for RPLIDAR A1 Motor	-	0V	-
Core Interface	VCC_5	Power	Power for RPLIDAR A1 Range Scanner Core	4.9V	5V	5.5V
	TX	Output	Serial output for Range Scanner Core	0V	-	5V
	RX	Input	Serial input for Range Scanner Core	0V	-	5V
	GND	Power	GND for RPLIDAR A1 Range Scanner Core	-	0V	V5.0

Figure 2-6 RPLIDAR A1 External Interface Specifications

Note: The batch version is a non-development kit and does not include the adapter board included in the development kit. For the motor interface and core interface of batch version, they use the PH1.25-3P horizontal pitch connector and PH1.25-4P vertical pitch connector respectively. The batch version does not provide cables. Please refer to the mechanical dimensions in Chapter 5 for details of signals and their matched pins. But the RPLIDAR development kit uses the PH2.54-7P pitch connector and a 7-pin connector. Please refer to *RPLIDAR*

Development Kit User Manual for detailed specifications.

Power Supply and Consumption

Ranging scanner system and motor system are powered separately in RPLIDAR A1. External system should provide power supply for them separately in order to ensure data accuracy. Below chart showed a recommended power mode. More specification is provided in the following table.

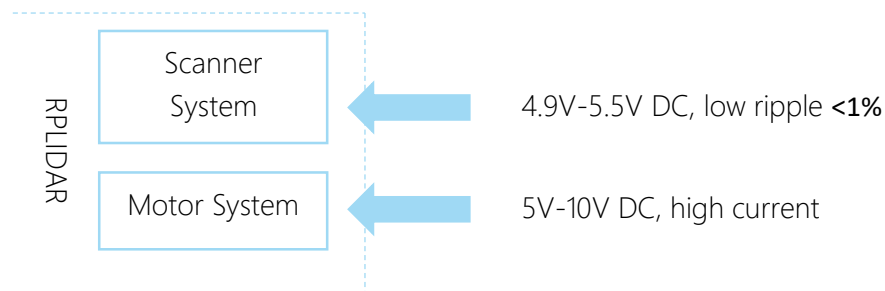

Figure 2-7 RPLIDAR A1 Power Recommended Power Mode

Item	Unit	Min	Typical	Max	Comments
Scanner voltage	system Volt (V)	4.9	5	5.5	If the voltage exceeds the max value, it may damage the core.
Scanner voltage ripple	system Millivolt(mV)		20	50	High ripple may cause the core working failure.
Scanner system start current	Milliampere (mA)	TBD	500	600	Underpower may cause the startup failure.
Scanner current	system Milliampere (mA)	TBD	80	100	Sleep mode, 5V input
		TBD	300	350	Work mode, 5V input
Motor system voltage	Volt (V)	5	5	10	Adjust voltage according to speed
Motor system current	Milliampere (mA)	TBD	100	TBD	5V input

Figure 2-8 RPLIDAR A1 Power Supply Specification

MISC

- For Model A1M8 Only

Item	Unit	Min	Typical	Max	Comments
Weight	Gram (g)	TBD	170	TBD	
Temperature range	Degree Celsius (°C)	0	TBD	0-45	

Figure 2-9 RPLIDAR A1 MISC Specification

To make sure RPLIDAR A1's laser always working in the safety range (<5mW) and avoid any other damage caused by device, RPLIDAR A1 comes with laser power detection and sensor healthy check feature. RPLIDAR A1 will shut down the laser and stop working when any of below errors has been detected.

- Laser transmit power exceeds limited value
- Laser cannot power on normally
- Scan speed of Laser scanner system is unstable
- Scan speed of Laser scanner system is too slow
- Laser signal sensor works abnormally

Host systems can inquiry the RPLIDAR A1's status through communication interface and restart RPLIDAR A1 to try to recovery from error.

SLAMTEC provides Framegrabber graphical debugging interface terminal for A1M8-R4 and the following models, as figure 4-1. And,SLAMTEC provides the Framegrabber plugin in RoboStudio for testing and debugging for A1M8-R5, as figure 4-2.In addition, SLAMTEC also provides SDK development kit under x86 windows, x86 Linux, arm Linux and other platforms.Please contact SLAMTEC for detail information.

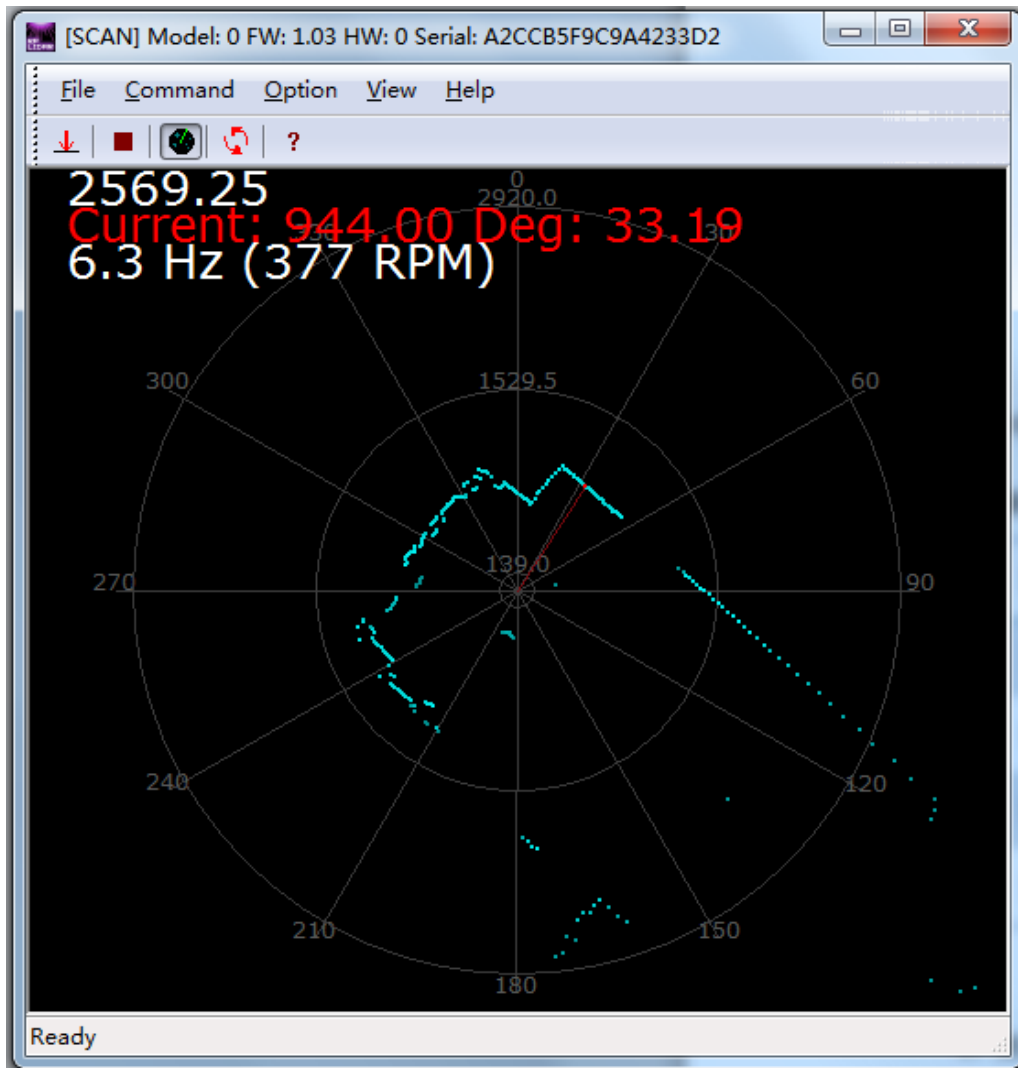

Figure 4-1 the Debugging GUI of RPLIDAR A1M8-R4 and the following models

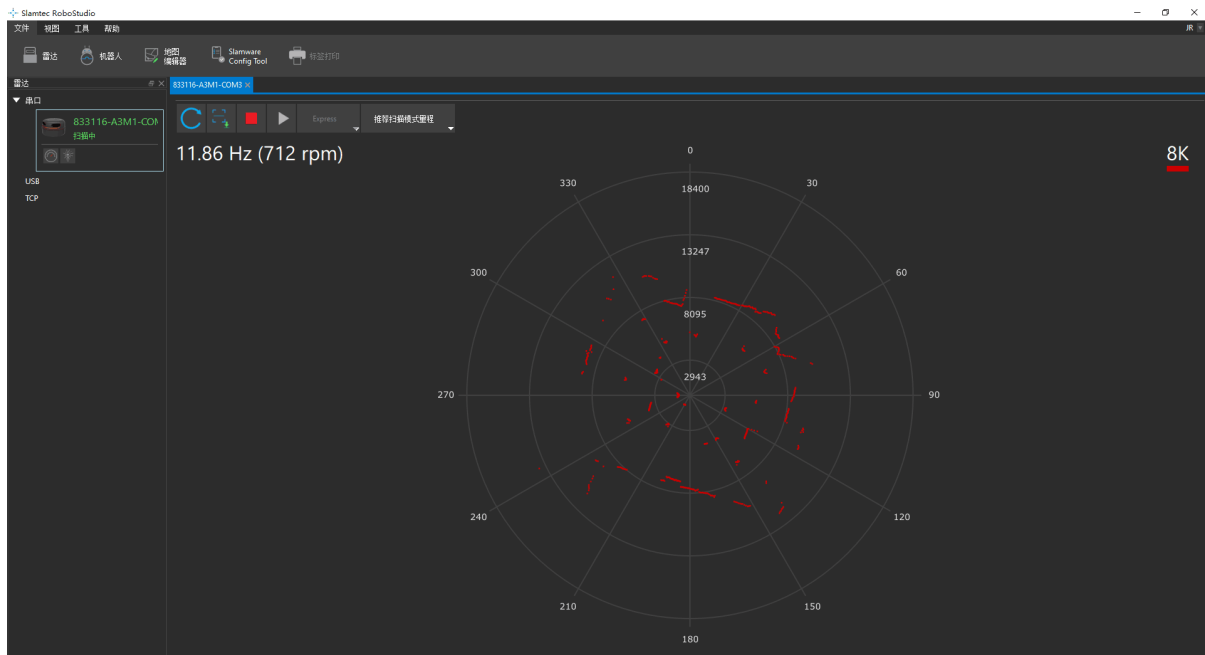

Figure 4-2 the Framegrabber Plugin in RoboStudio

For the ease of customer side integration, RPLIDAR A1's structure is designed to decouple the core ranging system and fixed platform which can be customized. The part marked red in the below figure is the fixed platform that can be customized according to customer requirement.

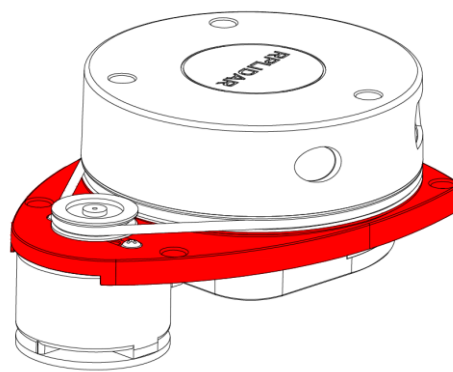

Figure 5-1 The fixed platform of RPLIDAR A1

The RPLIDAR A1-A1M8 assemble size showed below:

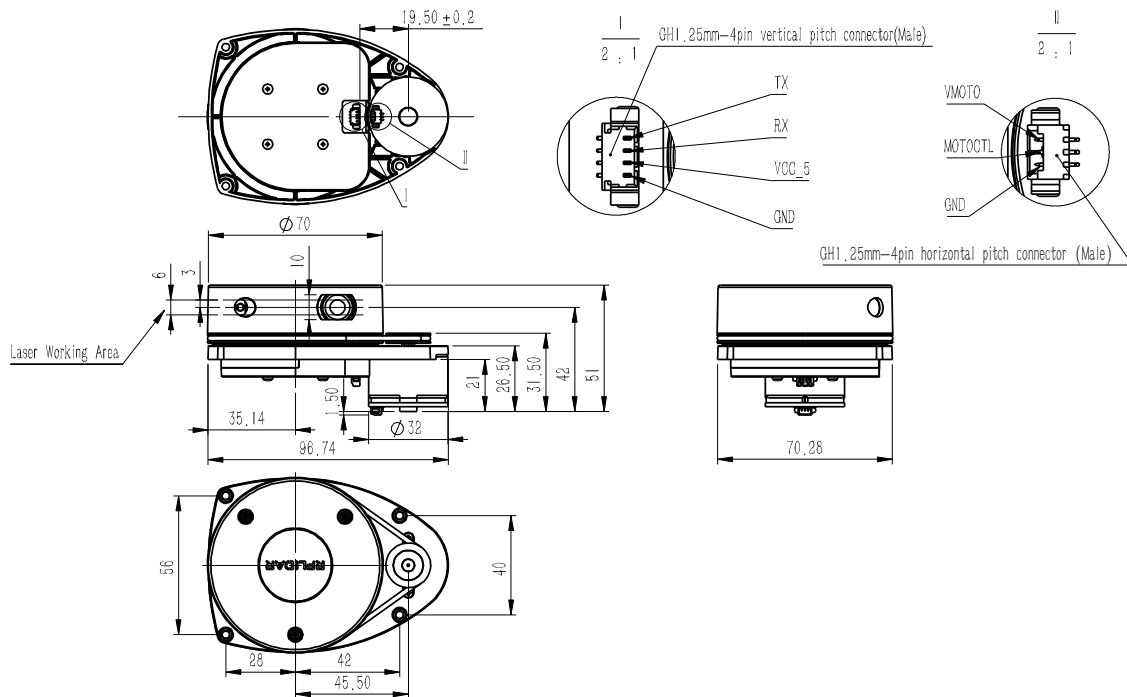

Figure 5-2 The Mechanical Dimensions of RPLIDAR A1

Date	Description
2013-3-13	Initial draft
2013-5-16	1. Updated the laser class information 2. Updated motor voltage range 3. Updated size chart according to Rev1.5 sample design
2013-8-9	Updated power consumption
2013-11-23	Updated product specification
2013-12-29	Updated product specification
2014-2-9	Added model name: A1M1
2014-4-17	Added weight and temperature range description
2014-5-6	Changed the measurement distance range based on the new design
2015-6-3	Update Mechanical parameter figure. Modify model name to A1M3
2016-3-29	Update Mechanical parameter figure. Modify model name to A1M8
2016-04-25	Added startup current requirement of A1M8 and corrected some parameter errors
2016-04-28	Added connection information for batch version
2016-05-19	Replaced obsolete images.
2016-07-04	Updated the description about RX input signal and added a note about it.
2017-11-22	Corrected the pin P4 maximum value from 6V to 5.5V in Figure 3-1.
2018-02-05	Alteration A1M8 models support 8K scan frequency. Add A1M8-R5 model
2018-09-26	Add product laser safety instructions and warnings, and last page product production instructions. Modify the difference between the batch version and the development kit version

Image and Table Index

FIGURE 1-1 RPLIDAR A1 SYSTEM COMPOSITION	3
FIGURE 1-2 THE RPLIDAR A1 WORKING SCHEMATIC	4
FIGURE 1-3 THE OBTAINED ENVIRONMENT MAP FROM RPLIDAR A1 SCANNING	5
FIGURE 1-4 THE RPLIDAR A1 SAMPLE POINT DATA INFORMATION	6
FIGURE 1-5 THE RPLIDAR A1 SAMPLE POINT DATA FRAMES	6
FIGURE 2-1 RPLIDAR A1 PERFORMANCE	8
FIGURE 2-2 THE TREND GRAPH OF RPLIDAR A1 RESOLUTION	8
FIGURE 2-3 RPLIDAR A1 OPTICAL SPECIFICATION	9
FIGURE 2-4 RPLIDAR A1 POWER INTERFACE	9
FIGURE 2-5 RPLIDAR EXTERNAL INTERFACE SIGNAL DEFINITION	10
FIGURE 2-6 RPLIDAR A1 EXTERNAL INTERFACE SPECIFICATIONS	10
FIGURE 2-7 RPLIDAR A1 POWER RECOMMENDED POWER MODE	11
FIGURE 2-8 RPLIDAR A1 POWER SUPPLY SPECIFICATION	11
FIGURE 2-9 RPLIDAR A1 MISC SPECIFICATION	12
FIGURE 4-1 THE DEBUGGING GUI OF RPLIDAR A1	14
FIGURE 5-1 THE FIXD PLATFORM OF RPLIDAR A1	15
FIGURE 5-2 THE MECHANICAL DIMENSIONS OF RPLIDAR A1	16

Manufacturer: SHANGHAI SLAMTEC CO., LTD.

Address: D-501 Shengyin Tower, 666 Shengxia Rd., Shanghai, China

Made in China